

BALETECH RECYCLING EQUIPMENT

“Pathfinder”

Model #504230-625

CLOSED DOOR HORIZONTAL BALER

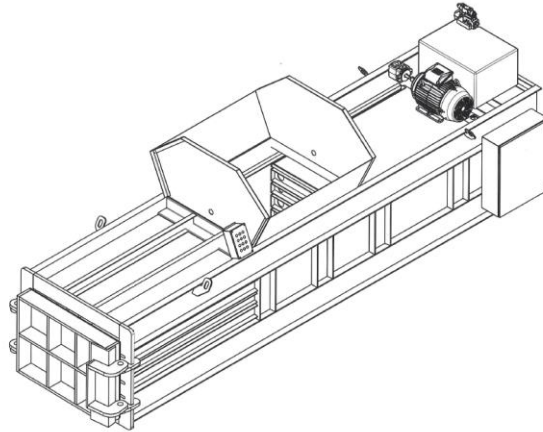

Standard Features:

- Closed Door Baler
- 6" x 3" Rod Main Cylinder
- 4" Door Cylinder
- 50"L x 42"W Feed Opening
- 25 HP TEFC Motor, Standard Voltage
208/440, 60 Hertz, 3 Phase
- 25 Gallon Pump
- Cycle Time: 30 Seconds
- PLC Logic Controlled
- Automatic Bale Full/Fault Indicator Light
- Automatic Cycle Eye Operation
- Replaceable Wear Liners
- 80 Gallon Oil Reservoir, Oil Included
- Standard Feed Hopper
- Replaceable Shear Blade
- 4 Wire Bale Tie
- Rear Mounted Power Unit
- Air to Oil Heat Exchanger
- UL Approved Panel
- Color: BALETECH Gray

STRUCTURAL SPECIFICATIONS

Bale Chamber	42" x 30" x 60"-65"
Feed Opening	50" x 42"
Baler Width	58"
Baler Height	71"
Baler Length	18 ft

PERFORMANCE DATA

Hydraulic System Pressure	3,000
Platen Force	84,800 lbs.
Platen PSI	67 PSI
Cycle Time	35 seconds
Bale Size	42" x 30" x 60-65"

HYDRAULIC SPECIFICATIONS

Motor	25 HP
Pump	25 GPM
Main Cylinder	6" x 60" x 3"
Door Cylinder	4" x 6"

NOTE: INFORMATION AND SPECIFICATIONS SUBJECT TO CHANGE WITHOUT NOTICE